

Planning for Operation of MicroGrids Considering Small Hydro Power Plants: Transient Stability

Sandra Ximena Carvajal Quintero
Member, IEEE

Department of Electrical, Electronic and
Computer Engineering
Universidad Nacional de Colombia
Manizales, Caldas
Email: sxcarvajalq@unal.edu.co

Juan David Marín Jiménez
Department of Electrical, Electronic
and Computer Engineering
Universidad Nacional de Colombia
Manizales, Caldas
Email: jdmarinj@unal.edu.co

Santiago Arango Aramburo
Department of Decision
and Computer Sciences
Universidad Nacional de Colombia
Medellin, Antioquia
Email: saarango@unal.edu.co

Abstract—The operation of the electrical distribution system for MicroGrids has the potential for important benefits for power systems, and can reduce the hazards and problems that may arise from its operation. Each MicroGrid presents different operating conditions, because it is shaped by factors that may vary depending on factors such as technology generation, load characteristics, regulations, market conditions, and geographic, economic and environmental circumstances. In this paper, we propose the implementation of a local system control of Small Hydroelectric Plants considered in the operation planning in the form of a MicroGrid. Intentional load outputs tests were performed with a power system simulation model. The model allows to observing the response of the control system and the transient behavior of the MicroGrid. Simulation results show that the implementation of a MicroGrid, the main system's variables remain within the ranges recommended by international standards; thus, there is a satisfactory behavior for an isolated operation mode of the transient stability.

Index Terms—Frequency control, Hydroelectric power generation, Microgrid, Performance analysis.

I. INTRODUCTION

A MicroGrid (μ G) is defined as a portion of a distribution system that can operate in parallel with the grid or isolated of it in case of partial or total disconnection from the electric power system. A μ G is made up of controllable and not controllable loads as well as distributed energy resources such as Distributed Generation (DG) and Storage Elements [1]. μ Gs are considered emerging king of operation of the distribution systems that have the ability to offer benefits to the operation of the electric power system and the society in general [2]; However, in order to implement this type of operation in an electrical distribution system, it is necessary to begin a planning process of the μ G that basically assesses the status and configuration of the current distribution system to propose and perform the required adjustments of the existing infrastructure [3].

Stability in the electric power systems is primarily, due to the planning and operation criteria used to design a system in which a possible number of contingencies and operating system conditions are assumed, they are: normal state, alert state, emergency state, extreme emergency state, and restorative state [4]. This same concept extends to the planning and operation

of the μ Gs. However, inertia is much lower in the μ Gs and it basically depends on the control elements of the generation and the load. The generation control system must be designed and modeled to generate in two operation modes: operating connected to the supply network and operating isolated from the mains supply [4]. When the μ G operates connected to the system, it does not represent a major challenge in the generation control since the stability depends on the inertia of the system, particularly of large power generation plants. However, when the μ G operates in isolation, the stability inside a μ G depends on the rapid response of the generation controllers to load changes and the selected control scheme during the planning of the μ G, to keep the voltage and frequency variables in the ranges allowed by the network operator [5]. Therefore, the control scheme of the generation requires special care because authors considered it as the most important criterion in the operation by μ G [6], [7].

This paper presents the intentional output tests carried out to verify the transient behavior of the μ G and the local control system response in a SHP that is considered in the planning for the operation of the system. The control system consists of a Woodward analogoelectronic PID speed controller and an IEEE excitation system Type 1 [8]. Testing was done on a simulation model named "Intermediate" μ G in MatLab/Simulink using the toolbox SimPowerSystems. This model allows carrying out dynamic studies of systems through the integration of blocks incorporated into the toolbox, particularly μ G operation.

The paper is organized as follows: in the second section presents an overview of the μ G, in the third section describes the case study, in the fourth section are performed simulations and presents the discussion of results obtained, and finally, in section five, general conclusions are made.

II. OVERVIEW OF MICROGRIDS (μ G)

Smart Grids and μ G shares three common objectives: *maximize generation of small scale assets through integration of intelligence, while greatly increasing the efficiency of the system, causing a reduction in operating cost.* [3]. A decade ago, international standards such as IEEE Std 1547™[9], did not recommend the islanded operation to utilities companies

worldwide. This sectors manifested security problems in operation and many barriers to achieving a retail competition between the independent power producer and local utilities or energy suppliers. However, the IEEE 1547.4 [10] provides approaches and best practices for the design, operation and integration of DG of isolated systems to power system. IEEE created a new term Distributed Resources island systems to generically refer to all intentional island systems that could include local and/or area Electrical Power Systems sometimes referred to as μ G. The term μ G is used for a Electrical Power System (EPS) that: have DG and load; have the ability to disconnect from and parallel with the area EPS; include the local EPS and may include portions of the area EPS, and are intentionally planned.

The concept of intentional islands, also called μ G, has been of interest for research centers and electric utilities around the world. In the last decade, has shown that the operation by μ G is feasible and has had many technical and economic benefits of pilot projects in different countries of the world [6], [11].

The benefits of μ G can be classified into two groups: (1) benefits arising from the use of Distributed Energy Resources (eg, clean generation, reduction of greenhouse gases, reduction of losses in transmission and distribution networks), and (2) profits derived from the operation by μ G (eg, improvement of the system efficiency, increased reliability, participation in programs that respond the demand, provision of ancillary services to the supply grid and within the μ G). Some study cases have shown that the benefits of the DG without the function to operation by the μ G, show less economic and technical benefits than the DG immersed in a properly planned μ G [12], [13], [14].

The concept of μ G can vary depending on the application and the context in which it is used. Some authors adapt definitions according to their needs and they specify different elements such as voltage levels, installed capacity, interconnection elements, use (commercial, industrial, etc.), resources (renewable or non-renewable), among others. However, this paper defines μ G as part of an Electric Power System which consists of sources of distributed generation and controllable loads (with control selectivity for critical and non critical loads) [1]; they operate as a single autonomous network, either in parallel or isolated from the power supply network. A very important feature is that the μ G should be intentionally planned [10].

Fig. 1 shows a μ G overview with the basic elements described in the above definition; the most outstanding elements that make up the μ G are: controllable DG, limited or not-controllable DG, energy storage elements, controllable load (to participate in Demand Response programs), and a μ G of administration and control center.

Several factors influence the success of the operation by μ G, the electrical system components (distribution networks, protection, maintenance) and the components of the operation by μ G itself. Below is a summary of the most important points in the planning and operation of a μ G [6]:

1) *Generator Governor*: This is the most important cri-

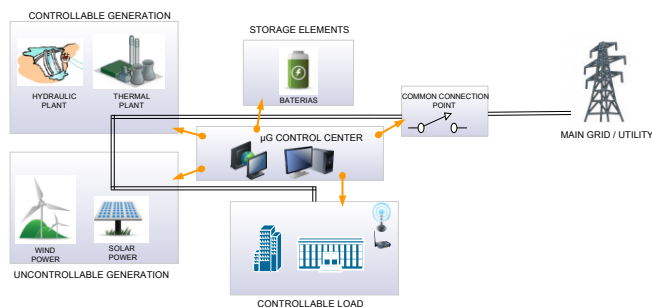

Fig. 1. Microgrid with a common point coupled to the electrical distribution system [15].

terion in the operation of a μ G. The governor must be designed and modeled in two operation modes: networked and isolated. In isolated mode, the governor should maintain the power quality within the μ G, within the limits allowed by the system operator. To avoid synchronism loss during reconnection to the network, the governor of the SHP must be equipped with a control unit designed to regulate the μ G frequency, voltage, and phasor in order to be close to network parameters.

- 2) *Operation and administration of the μ G*: A good strategy for planning a μ G allows smooth operation. Within this strategy the following aspects should be included: islands detection techniques, operation of the μ G connected to the network and isolated, and how to reconnect to the network. Various strategies have been proposed for the operation of a μ G [10], [16].
- 3) *Communication - Smart Grids*: A fast and reliable communication link is required to transfer control data and information [17].

Once the μ G operation concept and success criteria are established, the system description of the case study is made in order to identify the key elements and to quantify the magnitude of the μ G to be implemented.

III. METHODOLOGY

We initially reviewed the electric network distribution of the local operator named CHEC S.A. E.S.P. to identify operation opportunities of system fractions in the form of μ G. Once these operating possibilities were determined, we diagnosed the current state of the electricity infrastructure to allow proper operation by μ G. Then, we formulated an adjustment proposal for the DG networks and sources infrastructure; finally, we conducted an operation performance test in isolated mode of the μ G through load variations tests to observe the transient behavior of the μ G.

A. Case study

The local distribution system has 13.2 kV voltages, 33 kV and is interconnected with the Colombian Power System through 115 kV lines. This system consists of over 600 items including generators, loads, transformers and lines. Fig. 2 shows a fraction of the electrical system, with the circuits

closest to the planned μG . The local distribution system is entirely simulated. However, the equivalent of the Marmato substation network is used in order to perform the simulations in this research.

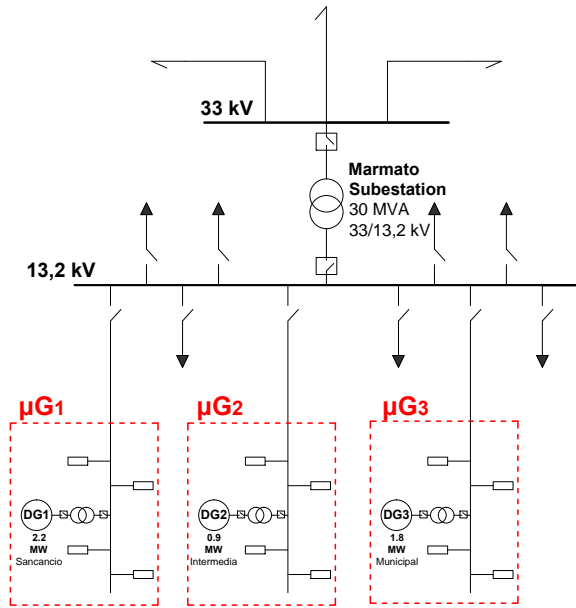

Fig. 2. System line diagram of the case study [18].

Fig. 2 shows three 13.2 kV feeders that have a SHP each one and whose capacities are 2.9, 1.4 and 2.6 MVA, for Sancancio, Intermedia, and Municipal respectively. Table I shows: the number of users per circuit, the quality indicators DES and FES, which measure the unavailability of the electricity service in terms of duration and frequency, and the availability factor of each circuit by 2012.

DES and FES indicators shown in Table I correspond to openings and duration of un scheduled interruptions in the three circuits of the case study. Additionally, FES and DES circuit indicators for programmed interruptions add an important value. These indicators can be reduced by enabling the operation by μG . Unscheduled interruptions have a greater negative impact on the end user.

B. Model of Simulation

Fig. 2 shows the single line diagram of the case study system. The single line diagram shows three μG with similar operating characteristics. In this study, the Intermedia μG was selected since it has the SHP with the highest capacity factor (0,55). The peak demand of the Intermedia circuit (study circuit) of the Marmato substation was 1.41 MVA in December 2011. Thus, the model of the Intermedia μG was made with MatLab/Simulink using SimPowerSystems toolbox, which allows dynamic studies of systems through the integration of predefined blocks in the toolbox.

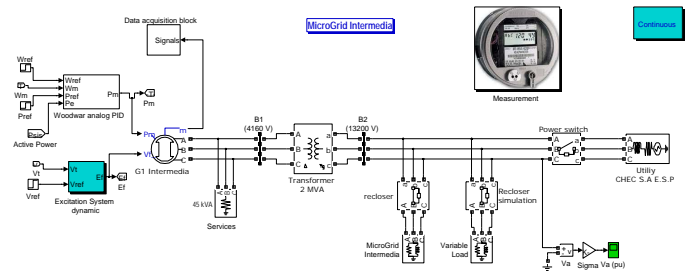

Fig. 3. Block diagram of the model of the μG Intermedia operating in isolation from the distribution system.

For the hydraulic turbine is employed first-order linear model, the transfer function used for this type of turbines is

$$\frac{\Delta P_m}{\Delta G} = \frac{1 - sT_w}{1 + s0,5T_w} \quad (1)$$

Where T_w is the start time of the water; P_m mechanical power of the turbine; G damper position or needles depending on the type of turbine. The model presented in Fig. 3 allows determining the dynamic behavior of the system when there is a sudden load output. The model is made up of the synchronous generator default block, the system block of the speed control, the excitation system block (the control system used is presented in Annexes), the three-phase transformer elevator block (4160/13200 V), the load of the Intermedia μG in an instant of time, a load block with a recloser to simulate sudden load outputs and a power switch that connects and disconnects the Intermedia μG with the National Interconnected System.

The simulations were conducted using the Woodward analog electronic PID speed controls, since the existing mechanical control in the current SHPs does not allow maintaining stability in the μG under load variations. Fig. 4 presents the response of two speed controls to a step-like signal representing a load variation. It also shows that mechanical control is not stable in a time range of 30 s, and that Woodward analog electronic PID control achieves a timely stabilization with acceptable magnitude variations of the generator output power. Therefore, the Intermedia μG simulations were done using Woodward analog PID speed control.

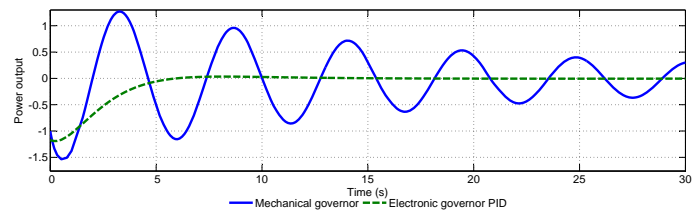

Fig. 4. Comparison of speed control response and existing speed control proposed.

To clarify the proper functioning and reliability of the system, three load outputs whose capacities correspond to three-phase commercial transformers, namely, 112.5 kVA, 225 kVA, and 300 kVA in the country were simulated. This was done in

TABLE I
 FEATURES MARMATO SUBSTATION CIRCUITS THAT ARE ASSIGNED A SHP. DATA [19]

Circuit Name	User number	FES (Frequency of occurrence)	DES (Duration of disturbance) [h]	Availability factor [%]	Plant factor[%]
Sancancio	4012	26	5,38	99,94	23,6
Intermedia	3305	21	4,02	99,95	55,3
Municipal	1200	47	12,89	99,83	35,7

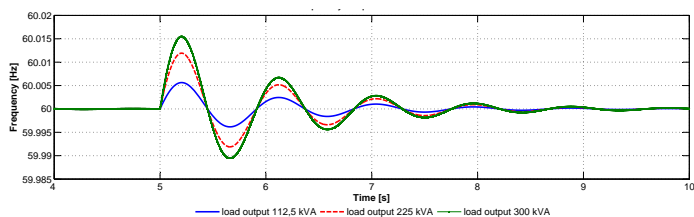

Fig. 5. Frequency response of the Intermedia Microgrid to changes in load.

order to observe the dynamic response of the controllers and the electrical parameters of the system.

IV. SIMULATION RESULTS

Below are the results of the simulations to changes in the load, the load outputs selection was made based on the capacity of the distribution transformers, which form the Intermedia μ G whose chargeability is less than 100% of the nominal capacity. Each test is composed of active and reactive power considering a typical residential inductive power factor of approximately 0.94. The power base of the system was 1400 kVA and the base voltage was 13200 V.

Fig. 5 shows the behavior of the frequency to changes in load output. The outputs were performed at 5 s after the μ G was operating in a steady state. The SHP response to load disconnection is a frequency increase to 15 mHz. This due to the raise in the angular speed of the operation. However, frequency is controlled and, approximately in 8 s, the μ G operates again at a nominal frequency.

To observe the response of frequency and voltage controllers of the Intermedia SHP synchronous generator, the behavior of the active and reactive power generator is observed in the Figs. 6 and 7. These controllers act when a portion of the μ G load (demand imbalance - generation) is disconnected. The active and reactive power of the generator is also reduced; the balance between power generated and demanded power depends on such reduction.

Additional the Figs. 6 and 7 show that the active and reactive powers of the generator decrease proportionally to the portion of the load disconnection to maintain μ G stable frequency and voltage, which shows the actual response of the controllers to suit the sudden disconnections of the demand. Variations are stabilized to the same extent because the μ G load was assumed to be fixed and the load outputs were simulated by connecting and disconnecting a load of different magnitudes through a disconnection device, named as simulation recloser in Fig. 3.

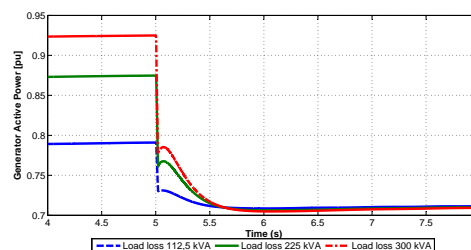

Fig. 6. Active power of the generator owing to load outputs in t= 5s.

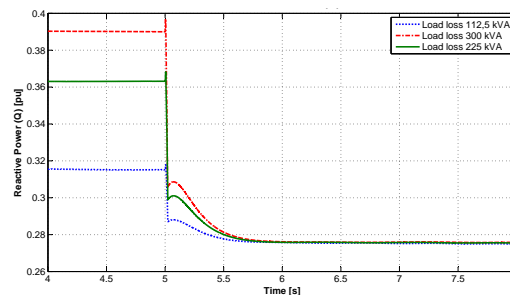

Fig. 7. Reactive power of the generator owing to load outputs in t= 5s.

V. DISCUSSION OF RESULTS

Simulation results show that the Intermedia μ G operates satisfactorily to sudden load outputs; moreover, the dynamic behavior of speed and voltage controllers used in the μ G have good performance. Therefore, the isolated operation mode of the Intermedia μ G is viable. The system is, however, incomplete, which means that in order to have successful planning, additional studies on load flow, short circuit, and protections coordination are required to properly determine its operation. Table II summarizes the tests conducted on the Intermedia μ G and the values of the main variables.

The response to sudden load outputs in all electrical parameters are consistent with international standards [20]. However, and according to the behavior of the frequency with load outputs, frequency protections that are installed on the generating units (over-frequency relay 81) must be adjusted since it is possible to trigger the generation unit when a considerable output load occurs. Additionally, it is recommended that the generation unit has a system independent boot (diesel generator) to supply ancillary services in case the generating unit is off and no network has the supply [21].

TABLE II
 TESTING LOAD OUTPUTS ON INTERMEDIA μ G

Test Name	Load output	Parameter variation				
		f_{max} [Hz]	ΔP [pu]	ΔQ [pu]	V [pu]	I [pu]
Load output 1	112,5 kVA	60,006	0,07	0,04	0,115	0,08
Load output 2	225 kVA	60,013	0,15	0,09	0,1	0,12
Load output 3	300 kVA	60,017	0,21	0,12	0,08	0,1

VI. CONCLUSIONS

In this paper, we conducted a simulation study of the μ G transient state through fast load change for the implementation of a control system of the SHPs. The model considered both voltage and frequency of the μ G. Our simulations depicts that the voltage and frequency operating limits remained within the ranges recommended by international standards for isolated systems operation. In fact, the isolated mode operation with the respective control system implemented in the SHPs enables operation of the local distribution electrical system in the form μ G.

Electrical μ Gs are presented as an operation alternative that allows boosting and profiting from DG benefits that have been unknown in the past. In Colombia, SHPs are the most common DG technology with great exploitation potential; with special importance nowadays given the large number of SHP under construction in Colombia. SHPs studies have shown that, with an appropriate control system, such technology allows proper μ G operation. In Colombia, such clear and renewable energy resource is available and suitable for a μ G operation. However there is a need for further research in different directions. On the one hand, we propose to analyze the requirements of both regulatory and technical adjustments of the Colombian power system for this implementation. On the other hand, additional studies on load flow, protections coordination and short circuit studies are required to determine the elements and adjustments necessary to properly operate.

REFERENCES

- [1] F. P. Sioshansi, Ed., *Smart Grid: Integrating Renewable, Distributed & Efficient Energy*. Waltham: Academic Press, 2011.
- [2] I. Koutsopoulos and L. Tassioulas, "Challenges in demand load control for the smart grid," *IEEE Network*, vol. 10, pp. 33–40, 2012.
- [3] H. Gharavi and R. Ghafurian., "Smart grid: The electric energy system of the future," *Proceedings of the IEEE*, vol. 99, pp. 917–921, 2011.
- [4] P. Kundur, *Power System Stability and Control*. London: McGraw-Hill Professional, 1994.
- [5] A. Mehrizi-Sani and R. Iravani, "Potential-function based control of a microgrid in islanded and grid-connected modes," *Power Systems, IEEE Transactions on*, vol. 25, no. 4, pp. 1883–1891, 2010.
- [6] H. Mohamad, H. Mokhlis, A. H. A. Bakar, and H. W. Ping, "A review on islanding operation and control for distribution network connected with small hydro power plant," *Renewable and Sustainable Energy Reviews*, vol. 15, no. 8, pp. 3952 – 3962, 2011. [Online]. Available: <http://www.sciencedirect.com/science/article/pii/S1364032111002632>
- [7] R. Caldon, A. Stocco, and R. Turri, "Feasibility of adaptive intentional islanding operation of electric utility systems with distributed generation," *Electric Power Systems Research*, vol. 78, pp. 2017–2023, 2008.
- [8] IEEE Std 421.5, "IEEE Recommended Practice for Excitation System Models for Power System Stability Studies," *IEEE Std 421.5 - 2005*, pp. 1–85, 2006.

- [9] IEEE Std 1547, "IEEE Standard for Interconnecting Distributed Resources With Electric Power Systems," *IEEE Std 1547-2003*, pp. 0 1–16, 2003.
- [10] IEEE Std 1547.4, "IEEE Guide for Design, Operation, and Integration of Distributed Resource Island Systems with Electric Power Systems," *IEEE Std 1547.4-2011*, pp. 1–54, 2011.
- [11] T. S. Ustun, C. Ozansoy, and A. Zayegh, "Recent developments in microgrids and example cases around the world - a review," *Renewable and Sustainable Energy Reviews*, vol. 15, no. 8, pp. 4030 – 4041, 2011. [Online]. Available: <http://www.sciencedirect.com/science/article/pii/S1364032111002735>
- [12] G. Y. Morris, C. Abbey, G. Joos, and C. Marnay, "A framework for the evaluation of the cost and benefits of microgrids," ERNEST ORLANDO LAWRENCE BERKELEY NATIONAL LABORATORY, Canada, Tech. Rep., 2011. [Online]. Available: <http://eetd.lbl.gov/EA/EMP/emp-pubs.html>
- [13] DTI, "Islanded operation of distribution networks," Distributed Generation Programme in support of the Technical Steering Group, United Kingdom, Tech. Rep., 2005. [Online]. Available: www.distributed-generation.gov.uk
- [14] NYSERDA, "Microgrids: An assesment of the value, opportunities and barriers to deployment in new york," Center for Energy, Marine Transportation and Public Policy at Columbia University, New York City, Tech. Rep., 2010. [Online]. Available: www.nysersda.org
- [15] J. D. Marín Jiménez, "Estudio del control de una pequeña central hidroeléctrica para la operación por microrredes en el sistema de distribución local," Master's thesis, Universidad Nacional de Colombia Sede Manizales, Manizales, Colombia, 2013.
- [16] H. D. Mathur, "Enhancement of power system quality using distributed generation," in *Power and Energy (PECon), IEEE International Conference on*, 2010, pp. 567–572.
- [17] M. Ropp, K. Aaker, J. Haigh, and N. Sabbah, "Using power line carrier communications to prevent islanding," in *Proceedings of the 2000 IEEE Photovoltaic Specialists Conference*, 2000, pp. 1675–1678.
- [18] S. X. Carvajal Quintero, J. D. Marin Jimenez, and S. Arango Aramburo, "Feasibility of intentional islanding operation with small hydropower plants," in *Transmission and Distribution: Latin America Conference and Exposition (T&D-LA), 2012 Sixth IEEE/PES*, 2012, pp. 1–6.
- [19] CHEC, "Estudio técnico migración de usuarios a niveles de tensión superiores (munts)," Central Hidroeléctrica de Caldas, Manizales, Caldas, Tech. Rep., 2012. [Online]. Available: <http://www.chec.com.co/sitioweb/flash/files/InformeDeMUNTS.pdf>
- [20] IEEE Std 1547.2, "IEEE Standard for Interconnecting Distributed Resources with Electric Power Systems," *IEEE Std 1547.2-2008*, pp. 1–54, 2008.
- [21] BChydro, "Distribution power generator islanding guidelines," BC Hydro, Canada, Tech. Rep., 2006. [Online]. Available: http://www.bchydro.com/content/dam/hydro/medialib/internet/documents/info/pdf/info_distribution_power_generation_islanding_june_2006.pdf

VII. BIOGRAPHIES

Sandra Ximena Carvajal Quintero graduated from Universidad Nacional de Colombia, Manizales, Colombia with M.Sc en Ph.D degrees in Electrical Engineering. Full professor, Universidad Nacional de Colombia. Her publications are in journals Energy policy. Field of interest: Ancillary services, System Dynamics and Electricity Markets.

Juan David Marín Jiménez Master's in Electrical Engineering, Universidad Nacional de Colombia. received his Electrical Engineer Degree at the same institution. Manizales, Colombia. His special fields of interests include: Distributed Generation, Renewable Energy, Electricity Markets and MicroGrids.

Santiago Arango Aramburo He is Associate Professor at Universidad Nacional de Colombia. He is a civil engineer, having earned his Masters degree from the same University, and his PhD from the University of Bergen, Norway. His research interests include the study of energy markets through simulation and experimental economics. His publications are in journals such as Energy Policy, Utilities Policy and Socio-Economic Planning, and he has published a book on the Colombian Electricity Market in 2008.